



Legacy Chillers, Inc.

Toll-Free: (877) 988-5464

Email: support@legacychillers.com

AIR-COOLED SEMI-HERMETIC CHILLERS

Packaged Chillers



*With
Easy-to-Use Touch Screen Display
on ALL Chiller Models
(located inside electrical cabinet)*



Electrical Cabinet
Inside

*Have Questions? Give Us a Call at: **877-988-5464***

Website: www.legacychillers.com

www.legacy-chillers.com

TABLE OF CONTENTS

Typical Legacy Chillers Chiller Applications	2
Nomenclature and Selection Procedure.....	3
16D - 88D Chillers - Capacity Table	4
Idec PLC Controller Features.....	5
Idec PLC Controller Features.....	6
Standard Features and Options.....	7
PSA - Packaged Unit Dimensional and Electrical Specifications	8
IESA - Split System Dimensional & Electrical Specifications.....	9
OC - Dimensional & Electrical Specifications.....	10
Glycol Correction Factor Table (back cover).....	Back



TYPICAL **LEGACY CHILLERS** – CHILLER APPLICATIONS

(but not limited to):

Commercial, Industrial & Residential Cooling Applications

- Air Conditioning
- Oil
- Injection Molding
- Plating Process
- Welding Machine
- Computer Room Air Conditioning
- Laser
- Dry Cleaning Machine
- Jacket Cooling
- Water-Cooled Condenser
- Printing Processing
- Swimming Pools
- Aquariums
- Fish Hatcheries
- Ice skating Rinks
- Commercial Ship Cooling Applications
- Low Temperature Process
- Plastics & Rubber Industries
- Military
- Anodizing Process Cooling
- Semiconductor Cooling
- Chemical
- Energy
- Plasma Cooling
- Data Center Cooling
- Cold Storage
- Extrusion Cooling
- Custom Cooling Innovation

Food & Beverage Industry Applications

- Bakery Processing
- Brewery
- Winery
- Drinking Water Fountain
- Batch Cooling
- Ice Machine Pre-Cool
- Fruit and Vegetable Washing and Processing
- Candy Manufacturing
- Dairy Cooling
- Soft Drink/Beverage Cooling

Medical & Pharmaceutical Applications

- M.R.I. Imager Cooling
- Operating Room Air Conditioning
- P.E.T. Scan
- C.A.T. Scan
- Lab Cooling
- Hypothermia Pads and Blankets
- Pharmaceutical Process Cooling

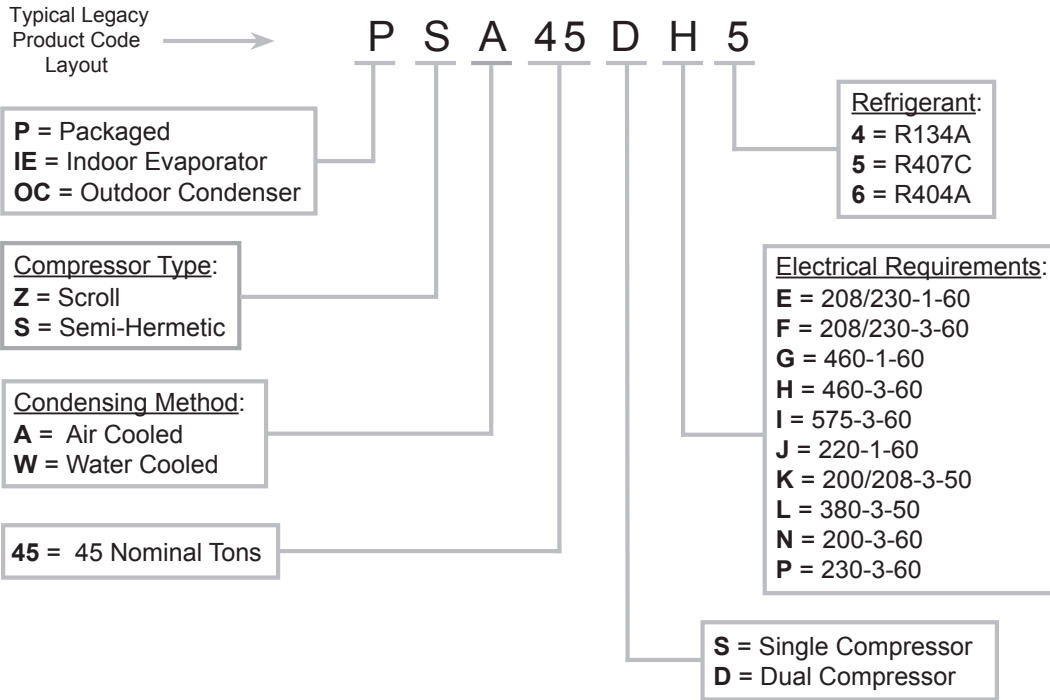

HOW TO PROPERLY SELECT AN AIR-COOLED PACKAGED CHILLER...

Caution



Low ambient, or lower leaving water temperatures, can require the recirculation of glycol solutions or other fluid blends.

These solutions can effect unit capacities.

Please consult the factory on these or other special applications for proper chiller and component sizing.

To properly select an Air-Cooled Packaged Chiller, the following information must be known:

1. The required cooling capacity, BTUH.
2. Delta T of entering and leaving fluid temperatures.
3. Fluid factor (ex. water = 500).
4. GPM of process fluid to be circulated.
5. Design ambient air temperature.

If you know any three of the above items 1 through 4 above, you can calculate the fourth by using the formulas below.

For 100% water:

- Cooling capacity (in BTUH) = GPM x Delta T x 500
- GPM = Capacity (in BTUH) / Delta T x 500
- Delta T = Capacity (in BTUH) / GPM x 500

Sample selection:

Select an air-cooled, packaged chiller to cool 108 GPM of 100% water from 54°F to 44°F. Design ambient air temperature 95°F. **Find:** Air-cooled chiller model.

Solution:

1. Chilled fluid Delta T = 54°F - 44°F = 10°F
2. Capacity (in BTUH) = 108 GPM x 10°F Delta T x 500 = 540,000 BTUH
3. From the PSA chiller capacity tables, it can be determined that the PSA45D has the capacity to meet the requirements.

Need Help... Just Give Us a Call... We are Here to Help!

16D - 88D Semi-Hermetic, Air-Cooled Chillers



Model Shown:
PSA88D

Chiller Model	Compressor Model	LWT °F	80			90			95			100			105		
			TONS	KW	EER	TONS	KW	EER	TONS	KW	EER	TONS	KW	EER	TONS	KW	EER
16D	3DA3R10ME	42	17.8	15.8	10.5	16.5	17.4	9.0	15.9	18.1	8.3	15.2	18.9	7.8	14.6	19.6	7.2
		44	18.6	15.9	10.9	17.3	17.5	9.3	16.6	18.2	8.6	15.9	19.0	8.1	15.3	19.7	7.5
		45	19.0	15.9	11.1	17.7	17.6	9.5	16.9	18.3	8.8	16.3	19.1	8.2	15.6	19.8	7.6
		50	21.2	16.0	12.3	19.7	17.8	10.5	18.9	18.7	9.6	18.2	19.6	8.9	17.4	20.4	8.2
19D	3DB3R12ME	42	21.1	18.6	10.9	19.7	20.5	9.3	18.9	21.4	8.6	18.2	22.3	7.9	17.4	23.1	7.4
		44	22.0	18.7	11.4	20.5	20.7	9.7	19.8	21.6	9.0	19.0	22.5	8.3	18.3	23.4	7.7
		45	22.5	18.7	11.6	21.2	20.7	9.9	20.2	20.7	9.2	19.4	22.7	8.5	18.7	23.6	7.9
		50	25.0	18.8	12.8	23.3	21.0	10.8	22.4	22.1	10.0	21.3	23.2	9.2	20.7	24.2	8.5
22D	3DF3R15ME	42	24.8	23.1	10.7	22.9	25.2	9.2	22.1	26.2	8.5	21.2	27.2	7.9	20.3	28.2	7.3
		44	25.8	23.3	11.1	24.0	25.5	9.5	23.0	26.6	8.8	22.1	27.6	8.2	21.2	28.6	7.6
		45	26.4	23.3	11.3	24.5	24.6	9.6	23.5	26.7	9.0	22.6	27.8	8.3	21.7	28.8	7.7
		50	29.4	23.7	12.4	27.3	26.2	10.5	26.2	27.4	9.7	25.1	28.6	8.9	24.1	29.8	8.3
25D	3DS3R17ME	42	28.0	25.8	10.3	26.0	28.3	8.9	25.1	29.4	8.3	24.2	30.6	7.7	23.3	31.7	7.2
		44	29.3	26.0	10.7	27.2	28.5	9.2	26.2	29.8	8.6	25.3	31.0	8.0	24.3	32.2	7.4
		45	30.7	26.1	10.9	27.8	28.7	9.4	26.8	29.9	8.7	25.8	31.2	8.1	24.8	32.4	7.5
		50	33.2	26.4	12.0	30.8	29.2	10.2	29.6	30.6	9.5	28.5	32.0	8.8	27.4	33.3	8.1
33D	4DBNR20ME	42	35.7	33.9	10.0	32.5	36.7	8.5	31.0	38.1	7.9	29.5	39.4	7.3	28.1	40.8	6.7
		44	37.3	34.2	10.4	34.2	37.2	8.8	32.5	38.6	8.2	31.0	40.0	7.6	29.4	41.4	7.0
		45	38.2	34.3	10.6	34.8	37.4	9.0	33.3	38.8	8.3	31.8	40.2	7.7	30.2	41.6	7.1
		50	42.7	34.7	11.7	39.2	38.1	9.9	37.5	39.7	9.2	35.7	41.4	8.4	34.0	42.8	7.8
37D	4DHNR22ME	42	41.0	37.5	10.6	36.8	40.2	9.0	34.8	41.4	8.3	32.8	42.6	7.6	31.1	43.8	7.0
		44	43.2	38.0	11.0	38.7	40.8	9.3	36.5	42.0	8.6	34.3	43.4	7.8	32.5	44.6	7.2
		45	44.2	38.3	11.2	39.5	41.0	9.5	37.3	42.4	8.7	35.2	43.6	8.0	33.3	44.8	7.4
		50	50.2	40.8	12.3	44.7	42.6	10.3	42.0	44.0	9.5	39.5	45.4	8.7	37.2	46.6	8.0
45D	6DBNR32ME	42	50.8	48.0	10.7	46.8	51.6	9.2	45.2	53.4	8.6	43.8	55.4	8.1	42.7	57.4	7.6
		44	52.8	48.2	11.0	48.8	52.2	9.5	47.2	54.2	8.9	45.8	56.2	8.3	44.7	58.4	7.8
		45	53.8	48.4	11.2	49.8	52.4	9.7	49.0	54.4	9.0	46.7	56.6	8.5	45.7	58.8	8.0
		50	58.5	48.8	12.1	54.3	53.4	10.4	52.8	55.8	9.7	51.5	58.4	9.1	50.5	61.0	8.6
55D	6DGNR37ME	42	59.7	60.4	9.8	56.0	63.6	8.7	54.5	65.8	8.2	53.3	68.0	7.8	52.5	70.2	7.5
		44	62.2	60.0	10.1	58.3	64.4	9.0	56.8	66.8	8.4	55.7	69.0	8.0	54.8	71.4	7.7
		45	63.5	60.2	10.3	59.5	64.8	9.1	58.0	67.2	8.6	56.7	69.6	8.1	55.8	72.0	7.8
		50	70.0	61.0	11.3	65.3	66.4	9.8	63.5	69.2	9.2	62.2	72.0	8.6	61.2	74.8	8.2
62D	6DJNR40ME	42	74.7	65.6	11.3	67.8	71.0	9.6	64.2	73.8	8.7	60.3	76.6	7.9	56.3	79.6	7.2
		44	78.7	66.4	11.8	71.8	71.8	10.0	68.0	74.8	9.1	64.0	77.8	8.3	59.8	81.0	7.5
		45	80.7	66.8	12.0	73.7	72.4	10.2	69.8	75.2	9.4	65.7	78.4	8.5	61.5	81.6	7.7
		50	90.2	78.6	13.1	82.8	74.4	11.2	78.8	77.6	10.3	74.3	80.8	9.4	69.8	84.4	8.5
71D	8DP3R56M	42	78.3	78.0	10.2	73.2	84.8	8.9	70.7	88.2	8.3	68.0	91.4	7.7	65.5	94.6	7.2
		44	81.6	78.8	10.6	76.3	85.8	9.2	73.6	89.4	8.5	71.0	92.8	8.0	68.3	96.0	7.4
		45	83.3	79.2	10.7	78.0	86.4	9.3	75.2	89.8	8.7	72.5	93.4	8.1	69.7	96.8	7.5
		50	92.3	80.6	11.7	86.3	88.6	10.1	83.3	92.4	9.4	80.4	96.2	8.7	77.4	100.0	8.1
88D	8DS3R67M	42	94.3	100.0	9.9	88.2	107.4	8.7	85.2	111.0	8.1	82.3	114.6	7.6	79.4	117.8	7.2
		44	98.2	101.0	10.2	92.0	109.0	8.9	88.8	112.6	8.4	85.9	116.2	7.9	82.9	119.8	7.3
		45	100.3	101.6	10.3	93.8	109.6	9.1	90.7	113.4	8.5	87.6	117.2	8.0	84.6	120.8	7.4
		50	110.5	104.0	11.1	95.7	113.0	9.7	100.1	117.2	9.1	96.8	121.4	8.5	93.7	125.7	7.9

1. Capacities on this chart are based on refrigerant R407C. Lower leaving water or low ambient can require the use of a glycol solution or other fluid blends. These solutions affect unit capacities. Please consult the factory on these or other special fluids.
2. KW input is for compressor(s) only.
3. EER = Energy Efficiency Ratio (BTU/watt-hour). Power inputs include compressor (s), condenser fan motor (s) and control power.

Touch Screen User Interface



Control Panel Shown for Model: PSA45DH6B

Touch Screen Key Chiller Control Features:

- USB update slot for **IN-PLACE** HMI and PLC software updates available from jmchillers.com
- Free Software Upgrades
- CE, UL Listed
- Monitor / Control your chiller from anywhere*
- 4gb SD card in slot for data storage - Standard
- Ultra bright display screen with auto screen saver
- Real-time Pressure and Temperature readings
- Automatic COMPRESSOR Lag/Lead with FIVE operational modes
- Automatic SYSTEM PUMP Lag/Lead with FIVE operational modes
- Factory configured for ALL chiller options

(Inside Mounted) Touchscreen Control Monitor



(PLC) Pentra Logic Controller

Other Touchscreen User Interface Examples...

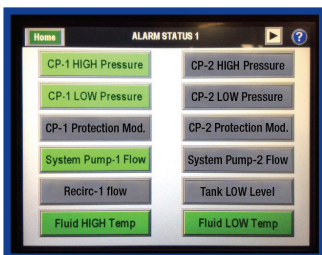

Alarm Status Screen 1

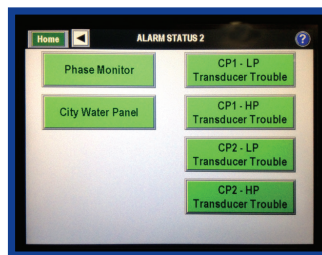

Alarm Status Screen 2

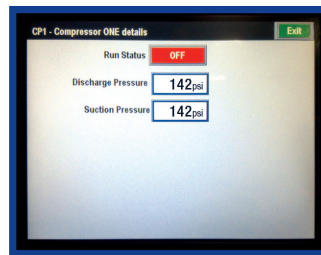

Compressor Operation Status and Pressures

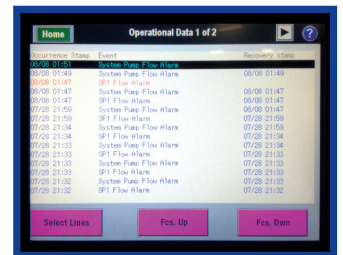

Operational Data and Fault Log

Pentra Microsmart, Programable Logic Controller (PLC)

Best-In-Class PLC available for ALL production chiller models.

Factory installed and programmed into your next Legacy Chiller. The **Pentra PLC** will seamlessly interface with our HMI touch screen.

Pentra Key features include:

- CE, UL Listed
- Highly accurate and fast performance
- Embedded Ethernet Port
- Modbus (Slave) TCP, RTU and ASCII for integration with most Building Automation Systems (BAS)
- Optional BacNet and LONWORKS communication protocols via third party gateway hardware
- Expandable I/O, ideal for custom chiller control projects
- I/O status indicators on for easy diagnostics

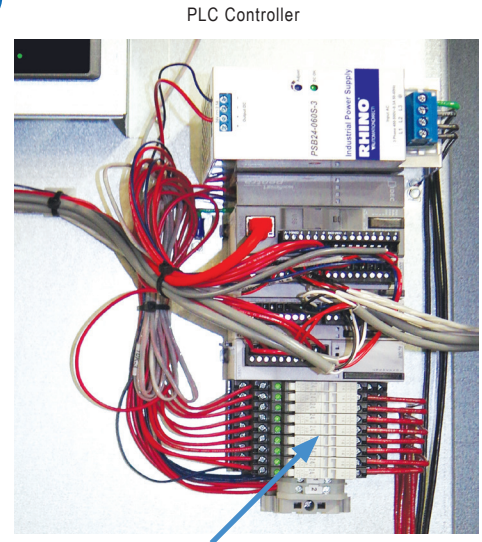

“Plugin” Control Relays for quick easy replacement. No circuit board to replace. Less downtime and cost.

Offering Extended Connectivity Options...

Up to 14 Simultaneous Connections!

Using Maintenance Communication Server connections, up to 3 Client devices, such as OI touchscreen, WindLDR software and SCADA OPC server such as WindSRV (KepServerEx), can simultaneously communicate with your MicroSmart Pentra PLC. Using Server Connections, an additional 8 connections can be established and each connection can be defined as Maintenance, User Communication or Modbus TCP server protocol. On top of that, another 3 connections can be configured as Modbus TCP client protocol, with a maximum of 255 requests. Each request can be for different slave devices with different IP addresses on the network.

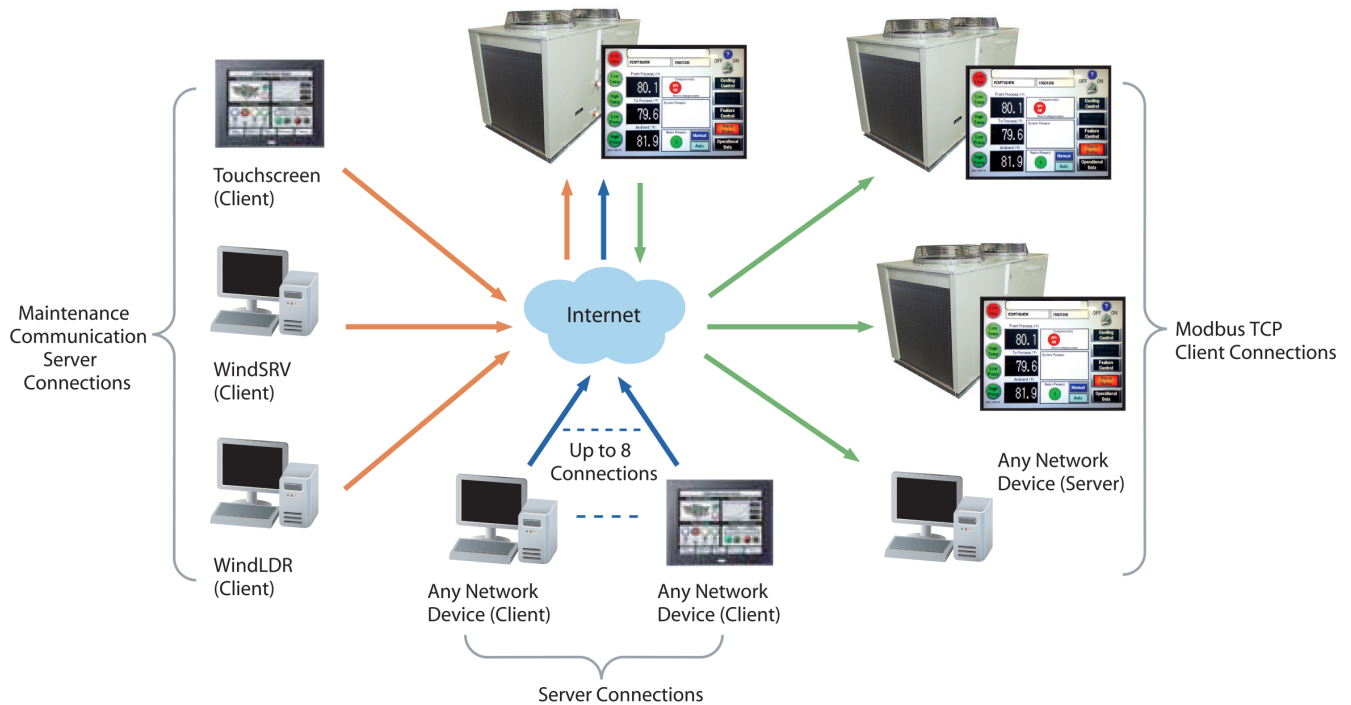

IMPORTANT CONSIDERATION: We offer an optional Level 3 managed switch allowing MODBUS connectivity to the Pentra MicroSmart PLC controller. In most cases, end users firewall settings will need to be updated to allow remote WAN connectivity.

Packaged Air-Cooled Semi-Hermetic Chillers

Standard Features (All Models):

- **ETL listed** to UL1995 & CAN/CSA C22.2 No. 236-11, 4th edition, 10/14/2011
- **Single point power connection**
- **Idec microprocessor controller with easy to use touch screen display**
- **STAINLESS STEEL**, brazed plate evaporator
- **Semi-Hermetic** compressor
- **Suction accumulator**
- **Water flow switch**
- **24V control transformer**
- Direct drive condenser fan motor
- Rust resistant, high CFM, aluminum condenser fan blade
- Condenser(s): copper tube/aluminum fin
- Compressor motor contactor
- Condenser motor and control circuit fusing
- **Painted (Powder Coated), galvanized sheet metal cabinet**
- 1/2" insulation on all water and Low pressure refrigerant lines
- Liquid line drier, sight glass, solenoid, TXV
- Complete refrigerant charge from factory



Available Options (All Models):

- ETL listed to UL1995 & CAN/CSA C22.2 No. 236-11, 4th edition, 10/14/2011
- Single Point Power Connection
- Idec microprocessor controller with easy to use HMI touch screen display
- STAINLESS STEEL, brazed plate evaporator
- SEMI-HERMETIC compressor with crankcase heater and vibration spring mounting kit
- Compressor discharge and suction pipe vibration eliminators
- Suction Accumulator
- Liquid sight-glass, solenoid, TXV and replaceable core drier
- Water flow switch
- 24V control transformer
- Fan cycle control (+40°F)
- Direct drive condenser fan motor
- Rust resistant, high CFM, aluminum condenser fan blade
- Condenser(s): copper tube/aluminum fin, Floating Tube T M
- 5 year condenser warranty against tube sheet leaks
- Compressor motor contactor
- Individual condenser motor contactors and fusing
- Condenser control panel with factory mounted door interrupt disconnect switch
- Galvanized steel sheet metal cabinet
- 1/2 inch insulation on all water and refrigerant lines
- Operating Refrigerant charge from factory

Split System Models Only:

- **Outdoor Condenser Section**
- Discharge and Liquid Line ball valves on indoor and outdoor equipment.

Tank Models Only:

- Storage Tank Sight Glass
- Tank low liquid level indicator with dry contacts

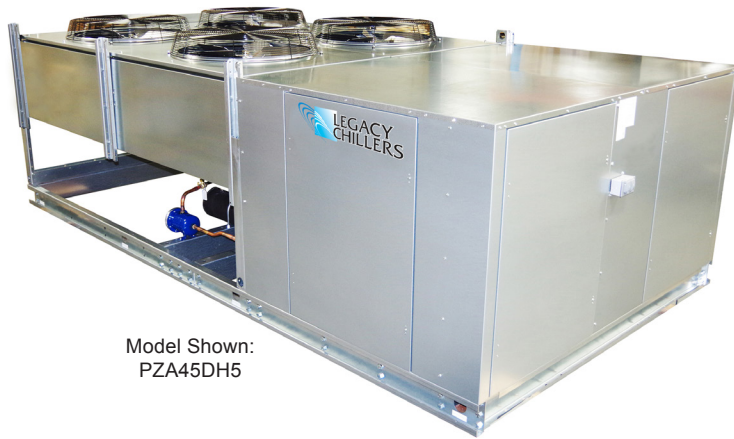

Model Shown:
PSA45DH5

Dual Circuit Packaged Semi-Hermetic, Air-Cooled Chillers

Chiller Model	Nominal BTUH @ 44°F	Length Inches	Width Inches	Height Inches	Fluid Conn.	Compressor			RLA Ea.	LRA Ea.	Fan Motor		MCA	M.O.P.	Chiller WT LBS
						Qty.	HP	Model			Qty.	FLA ea.			
PSA16DF5	199,200	176.5	45	55	2" FPT	2	8	3DA3R10ME	36.8	215	2	7	100	125	3200
PSA16DH5									17.9	106		3.5	50	60	
PSA16DI5									14.7	84		2.8	40	50	
PSA19DF5	237,600	176.5	45	55	2" FPT	2	10	3DB3R12ME	39.1	215	2	7	110	140	3500
PSA19DH5									17.9	106		3.5	50	60	
PSA19DI5									14.8	84		2.8	40	50	
PSA22DF5	276,000	176.5	45	55	2" FPT	2	12.5	3DF3R15ME	43.2	275	2	7	125	150	3700
PSA22DH5									21.2	138		3.5	60	70	
PSA25DF5	314,400	230	45.5	55	2" FPT	2	15	3DS3R17ME	53.5	275	3	7	150	175	4000
PSA25DH5									26.0	138		3.5	70	90	
PSA25DI5									21.2	110		2.8	60	70	
PSA33DF5	390,000	180	89	55	2" FPT	2	17	4DBNR20ME	76.9	374	4	7	225	250	4700
PSA33DH5									38.5	187		3.5	110	125	
PSA33DI5									30.1	135		2.8	80	100	
PSA37DF5	438,000	180	89	55	2.5" FPT	2	20	4DHNR22ME	96.2	428	4	7	250	300	4900
PSA37DH5									48.1	214		3.5	125	150	
PSA37DI5									34.8	172		2.8	90	110	
PSA45DF5	566,400	180	89	55	2.5" FPT	2	25	6DBNR32ME	122.9	565	4	7	350	400	5100
PSA45DH5									51.7	283		3.5	150	175	
PSA45DI5									44.9	230		2.8	125	150	
PSA55DN5	681,600	230	89	57	3" FPT	2	30	6DGNR37ME	155.1	650	6	7	400	500	6000
PSA55DP5									141.7	594		7	400	500	
PSA55DH5									73.7	297		3.5	200	250	
PSA55DI5									51.6	245		2.8	150	175	
PSA62DN5	816,000	230	89	57	3" FPT	2	35	6DJNR40ME	167.9	754	6	7	450	500	6200
PSA62DP5									142.3	594		7	400	500	
PSA62DH5									71.8	297		3.5	200	250	
PSA62DI5									58.3	245		2.8	150	200	
PSA71DF5	883,200	230	89	57	4" FPT	2	50	8DP3R56M	161.5	1070	6	7	450	600	6500
PSA71DH5									80.9	535		3.5	225	250	
PSA71DI5									67.3	405		2.8	175	225	
PSA88DF5	1,065,600	230	89	57	4" FPT	2	60	8DS3R67M	201.3	1070	6	7	500	600	6700
PSA88DH5									100.6	535		3.5	250	300	
PSA88DI5									71.8	405		2.8	200	250	

1) The calculations for the MCA and MOP are based on requirements of NFPA 70, the National Electrical Code (NEC) and CSA C22.1, the Canadian Electrical Code (CEC). The MCA is the minimum wire size needed to guarantee that the wiring will not overheat under any operating conditions. The MOP is the maximum allowable circuit breaker size that will properly disconnect power to the equipment under any anticipated fault condition.

2) Weights are based on models with standard features only. Weights will increase with each added option. Consult factory.

Dual Circuit Split-System Semi-Hermetic, Air-Cooled Chillers

Chiller Model	Length Inches	Width Inches	Height Inches	Water Conn.	Refrig Conn		Compressor			RLA Ea.	LRA Ea.	Condenser Model	Fan Motor Qty	FLA ea	MCA	M.O.P.	Chiller WT LBS
					Disch	Liquid	Qty	HP	Model								
IESA16DF5	85	34	45	2" MPT	7/8"	5/8"	2	8	3DA3R10ME	36.8	215	OC16D	2	7	100	125	1050
IESA16DH5										17.9	106			3.5	50	60	
IESA16DI5										14.7	84			2.8	40	50	
IESA19DF5	85	34	45	2" MPT	1-1/8"	5/8"	2	10	3DB3R12ME	39.1	215	OC19D	2	7	110	140	1100
IESA19DH5										17.9	106			3.5	50	60	
IESA19DI5										14.8	84			2.8	40	50	
IESA22DF5	85	34	62	2" MPT	1-1/8"	5/8"	2	12.5	3DF3R15ME	43.2	275	OC22D	2	7	125	150	1200
IESA22DH5										21.2	138			3.5	60	70	
IESA25DF5	85	34	62	2" MPT	1-1/8"	5/8"	2	15	3DS3R17ME	53.5	275	OC25D	3	7	150	175	1400
IESA25DH5										26.0	138			3.5	70	90	
IESA25DI5										21.2	110			2.8	60	70	
IESA33DF5	85	34	62	2" MPT	1-3/8"	7/8"	2	17	4DBNR20ME	76.9	374	OC33D	4	7	225	250	1600
IESA33DH5										38.5	187			3.5	110	125	
IESA33DI5										30.1	135			2.8	80	100	
IESA37DF5	85	34	62	2" MPT	1-3/8"	7/8"	2	20	4DHNR22ME	96.2	428	OC37D	4	7	250	300	1700
IESA37DH5										48.1	214			3.5	125	150	
IESA37DI5										34.8	172			2.8	90	110	
IESA45DF5	110	34	62	2.5" MPT	1-5/8"	7/8"	2	25	6DBNR32ME	122.9	565	OC45D	4	7	350	400	1800
IESA45DH5										51.7	283			3.5	150	175	
IESA45DI5										44.9	230			2.8	125	150	
IESA55DN5	110	34	62	2.5" MPT	1-5/8"	1-1/8"	2	30	6DGNR37ME	155.1	650	OC55D	6	7	400	500	1900
IESA55DP5										141.7	594			7	400	500	
IESA55DH5										73.7	297			3.5	200	250	
IESA55DI5										51.6	245			2.8	150	175	
IESA62DN5	110	34	62	2.5" MPT	1-5/8"	1-1/8"	2	35	6DJNR40ME	167.9	754	OC62D	6	7	450	500	2200
IESA62DP5										142.3	594			7	400	500	
IESA62DH5										71.8	297			3.5	200	250	
IESA62DI5										58.3	245			2.8	150	200	
IESA71DF5	120	34	68	2.5" MPT	1-5/8"	1-1/8"	2	50	8DP3R56M	161.5	1070	OC71D	6	7	450	600	2500
IESA71DH5										80.9	535			3.5	225	250	
IESA71DI5										67.3	405			2.8	175	225	
IESA88DF5	120	34	68	2.5" MPT	2-1/8"	1-1/8"	2	60	8DS3R67M	201.3	1070	OC88D	6	7	500	600	2800
IESA88DH5										100.6	535			3.5	250	300	
IESA88DI5										71.8	405			2.8	200	250	

3) See Installation Instruction Manual Refrigerant Chart for additional refrigerant charge needed for extended pipe length.
 1) The calculations for the MCA and MOP are based on requirements of NFPA 70, the National Electrical Code (NEC) and CSA C22.1, the Canadian Electrical Code (CEC). The MCA is the minimum wire size needed to guarantee that the wiring will not overheat under any operating conditions. The MOP is the maximum allowable circuit breaker size that will properly disconnect power to the equipment under any anticipated fault condition.

2) Weights are based on models with standard features only. Weights will increase with each added option. Consult factory.

3) See Installation Instruction Manual Refrigerant Chart for additional refrigerant charge needed for extended pipe length.

4) See condenser specification sheet for weight and dimension specifications.

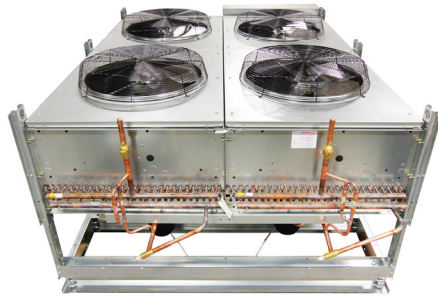

Model Shown:
OC45DH5

Split-System Outdoor Condenser

Model	Length Inches	Width Inches	Height Inches	Fan Motor		Refrigerant Conn.		Weight Pounds
				Qty	HP	Discharge	Liquid	
OC16D	127	45.56	49.13	2	1.5	7/8"	5/8"	580
OC19D	127	45.56	49.13	2	1.5	1 1/8"	5/8"	630
OC22D	127	45.56	49.13	2	1.5	1 1/8"	5/8"	680
OC25D	180	45.56	49.13	3	1.5	1 1/8"	5/8"	930
OC33D	127	88	49.13	4	1.5	1 3/8"	7/8"	1240
OC37D	127	88	49.13	4	1.5	1 3/8"	7/8"	1340
OC45D	127	88	49.13	4	1.5	1 5/8"	7/8"	1440
OC55D	180	88	49.13	6	1.5	1 5/8"	1 1/8"	1990
OC62D	180	88	49.13	6	1.5	1 5/8"	1 1/8"	1990
OC71D	180	88	49.13	6	1.5	1 5/8"	1 1/8"	2140
OC88D	180	88	49.13	6	1.5	2 1/8"	1 1/8"	2140

1) Weights are based on models with standard features only. Weights will increase with each added option. Consult factory.

OC16D, 19D, 22D

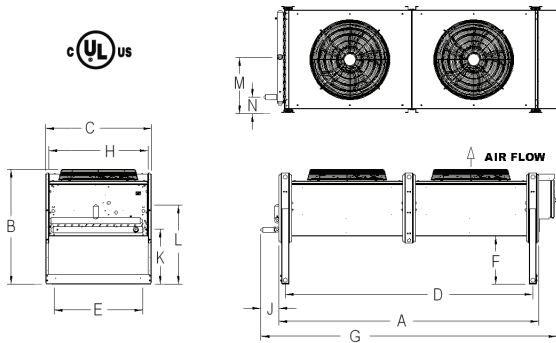

OC25D

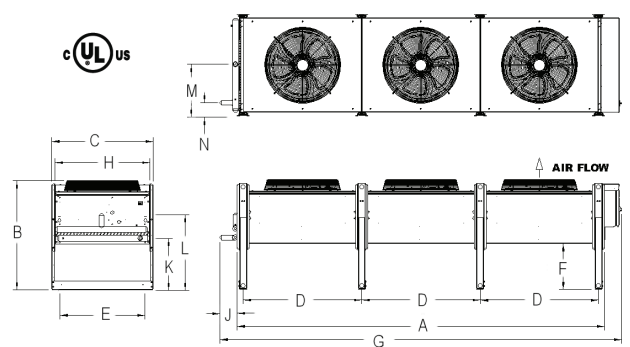

OC33D, 37D, 45D

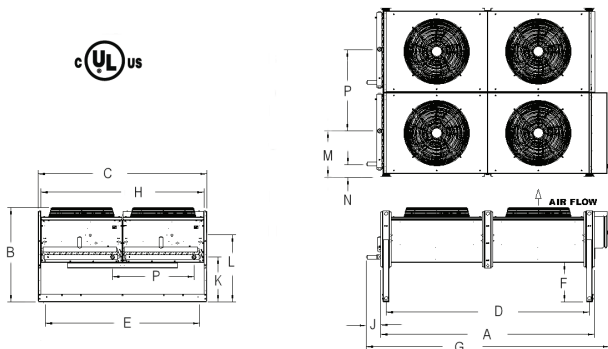

OC55D, 62D, 71D, 88D

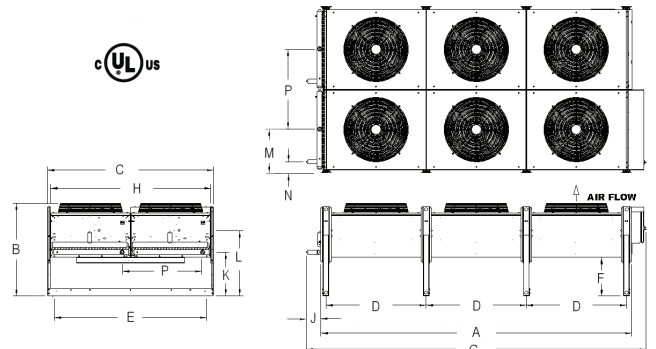

AIR-COOLED SEMI-HERMETIC

GLYCOL CORRECTION FACTOR TABLES

PROPYLENE GLYCOL CAPACITY CORRECTION FACTOR TABLE							
PERCENT PROPYLENE GLYCOL BY WEIGHT	15%	20%	25%	30%	35%	40%	50%
FREEZING POINT IN °F	24	18	15	9	5	-5	-30
CAPACITY FACTOR MULTIPLIER*	0.992	0.986	0.972	0.960	0.950	0.928	0.878
PRESSURE DROP MULTIPLIER	1.04	1.08	1.13	1.21	1.26	1.47	2.79
ETHYLENE GLYCOL CAPACITY CORRECTION FACTOR TABLE							
PERCENT ETHYLENE GLYCOL BY WEIGHT	10%	15%	20%	25%	30%	35%	40%
FREEZING POINT IN °F	25	21	17	11	5	0	-10
CAPACITY FACTOR MULTIPLIER*	0.98	0.96	0.95	0.93	0.92	0.91	0.89
PRESSURE DROP MULTIPLIER	1.08	1.11	1.16	1.21	1.27	1.32	1.38

* At standard ARI 590 conditions: 54°F entering fluid temperature, 44°F leaving fluid temperature, 95°F ambient temperature, 0.0005 fouling.



Legacy Chillers, Inc.
 851 Tech Drive
 Telford, PA. 18969

Email: support@legacychillers.com
Website: www.LegacyChillers.com
www.legacy-chillers.com